

Honoured with:



Cassette awning

# Opal Design II

## Opal Design II LED | Valance Plus | LED Valance Plus

The **Opal Design II** cassette awning stands out for its timeless, classic design hand in hand with groundbreaking weinor technology. Made to shade large areas, it blends in harmoniously with its surrounding architecture, the attractive shape of the cassette adding a sophisticated element. A wide range of tempting and practical optional extras make it easy to operate and wonderfully convenient while also extending its lifetime.

**ShadeZone**  
Alfresco Specialists

**Wind lock safety device:**

The ultramodern technology prevents the awning from lifting up when wind gusts from below

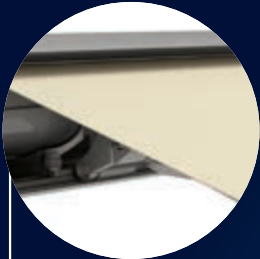

**End cap closure:**  
Unique and safe closing mechanism

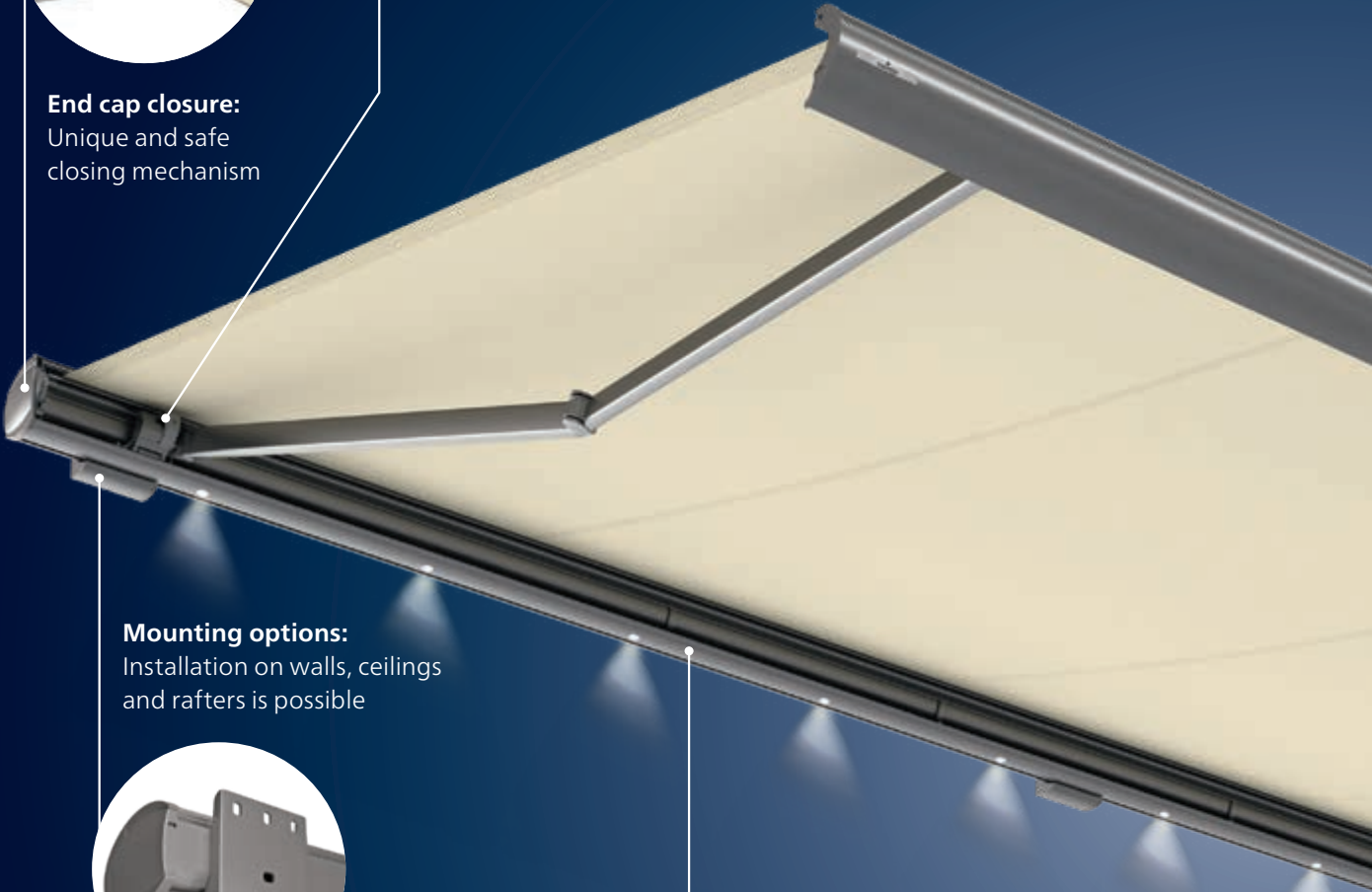

**Mounting options:**  
Installation on walls, ceilings and rafters is possible



Wall mounting



Ceiling mounting



Rafter mounting

**Opal Design II LED (optional):**  
Integrated lighting



# Opal Design II Highlights



**Awning cassette:**  
Classic design with the latest technology

**Versions:**

Valance Plus

Multi-section units



**weinor LongLife arm:**  
Very durable and low-noise



# Opal Design II Benefits



## Cassette awning – classic design with the latest technology

Classic, timeless design plus superior high-tech elements are united in the top-class weinor Opal Design II awning.

- Cassette is just 16 cm high: particularly flat, attractive shape
- Smart cassette design for the utmost stability and safety

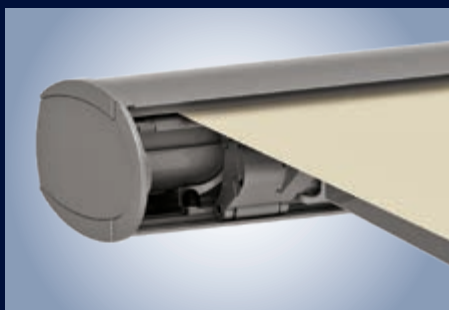

## End cap closure – unique and safe closing mechanism

If you can see that the crescent-shaped caps at the sides are closed then the awning is reliably protected against damp and dirt.

- Unique, patented weinor technology
- The only awning on the market with this USP



## LEDs and Valance Plus – integrated lighting and vertical protection

The Opal Design II LED variant adds integrated “warm light” LED lighting to the awning

- Individual LED spotlights integrated into awning cassette
- Dimmable when used with BiConnect or Somfy io-homecontrol® radio control

The Opal Design II Valance Plus option provides vertical protection against the sun and prying eyes.

- Attractive fabric combinations
- Patented weinor OptiFlow-System® to keep fabric ideally positioned and to close the drop profile safely

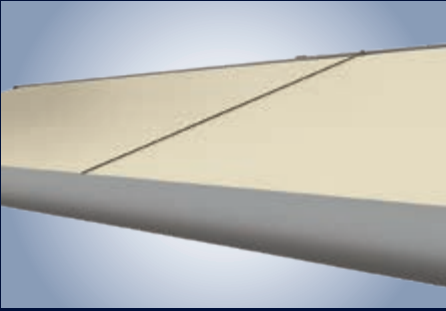

### Multi-section units – to shade especially large areas

The Opal Design II also comes as a combined multi-section unit for very large terraces.

- As a 2-part unit up to 1,200 cm
- Jockey cover: easy to fit
- Coupled version not possible with Valance Plus



### Wind lock safety device – reliable protection

The ultramodern technology prevents the awning from lifting up when wind gusts from below.

- Patented wind lock safety device
- Via a tilting member, the drop profile and awning arm are tilted when ascending
- Proven, maintenance-free technology
- All components made of forged and extruded aluminium



### weinor LongLife Arm – durable, quiet operation

The weinor LongLife arm features an exceptionally robust high-tech belt.

- Tested to more than 100,000 cycles
- Extremely quiet operation
- No maintenance required
- Drop forged aluminium in joint – light but highly robust

# Opal Design II Technology

Versions of Opal Design II	Opal Design II	Opal Design II LED
<b>Technology</b>		
Max. width, 1-section/2-section with jockey cover	650 cm/1,200 cm	650 cm/1,200 cm
Max. projection	400 cm	400 cm
Cassette size (w x h) incl. standard bracket	265 mm x 172 mm	265 mm x 172 mm
Coupled systems	<input type="radio"/>	<input type="radio"/>
Gear drive	<input type="radio"/>	—
Motor drive	<input checked="" type="radio"/> as standard	<input checked="" type="radio"/> as standard
Angle of pitch on awning	5° – 40° (with projection from 360 cm 7° to 40°)	5° – 40° (with projection from 360 cm 7° to 40°)
Installation alternatives	Can be installed on walls, ceilings and rafters	
LED lighting (separate spotlights)	—	<input checked="" type="radio"/> integrated into the awning's cassette
Patented weinor Opti-Flow-System®	<input checked="" type="radio"/> as standard	<input checked="" type="radio"/> as standard
LongLife arm	<input checked="" type="radio"/> as standard	<input checked="" type="radio"/> as standard
<b>Valance Plus option</b>		
Max. width	500 cm/600 cm	500 cm/600 cm
Max. awning projection	350 cm/300 cm	350 cm/300 cm
Cassette size (w x h)	326 x 160 mm	326 x 165 mm
Gear drive	<input type="radio"/>	<input type="radio"/>
Motor drive	<input checked="" type="radio"/> as standard	<input checked="" type="radio"/> as standard
Angle of pitch on awning	10° to 20°	10° to 20°
Valance Plus projection (h)	100 cm, 150 cm, 210 cm	100 cm, 150 cm, 210 cm
Patented weinor Opti-Flow-System®	<input checked="" type="radio"/> as standard	<input checked="" type="radio"/> as standard
<b>Accessories</b>		
Tempura/Tempura Quadra heating system for Opal Design II/LED	<input type="radio"/> bracket with special attachment	<input type="radio"/> bracket with special attachment
BiSens Agido-3V product protection sensor	<input type="radio"/>	<input type="radio"/>
<b>Controls</b>		
Radio control	<input type="radio"/>	<input type="radio"/>
No remote	<input checked="" type="radio"/>	<input checked="" type="radio"/>
<b>Weather sensors</b>		
Sun/wind sensor BiConnect BiSens SW-230V	<input type="radio"/>	<input type="radio"/>
Sun/wind sensor solar powered BiConnect BiSens SW-Solar+	<input type="radio"/>	<input type="radio"/>
Sun/wind/rain sensor BiConnect-BiSens-SWR-230V	<input type="radio"/>	<input type="radio"/>
<b>Quality</b>		
Tested up to	wind resistance class 2 according to DIN 13561 (wind strength 5 on the Beaufort scale)	

standard  optional — unavailable

Some options are subject to a surcharge. For prices, please refer to the weinor awnings price list.

# Opal Design II LED

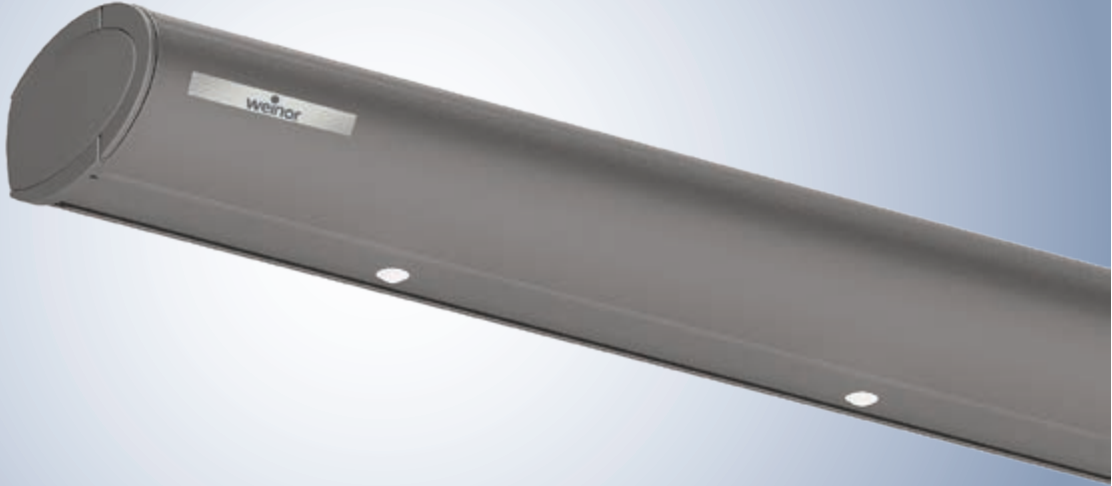

## LED lighting – 30,000 hours of lighting require minimal energy consumption

- Select LED components for top weinor quality:
- Integrated into the cassette
  - Atmospheric light thanks to special glass lenses
  - Lighting remains on even when awning is retracted
  - Highly energy-efficient
  - Operating life of 30,000 hours
  - Dimmable when used with BiConnect or Somfy io-homecontrol® radio control
  - Easy to service: simply replace individual LED lights without uninstalling the awning



**The receiver, power supply pack and other electrical components, such as the BiConnect receiver are integrated into the cassette**

The transformer box can be easily be opened for servicing purposes. The receiver, which is separate from the drive, is then easily accessible.

### Integrated LED lighting

Awning width in cm	Number of separate LED spotlights	Awning width in cm	Number of separate LED spotlights
187 – 219 cm	3	440 – 494 cm	8
220 – 274 cm	4	495 – 549 cm	9
275 – 329 cm	5	550 – 603 cm	10
330 – 384 cm	6	604 – 650 cm	11
385 – 439 cm	7		

# Opal Design II Valance Plus

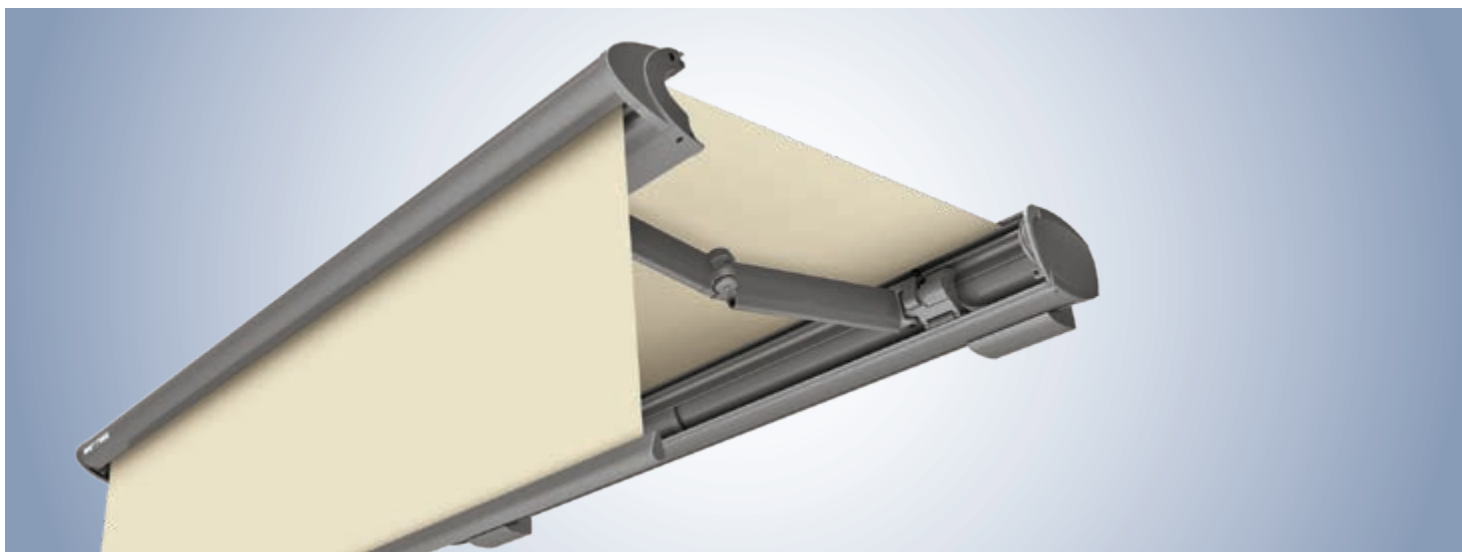

## More privacy thanks to vertical privacy and sun screen (optional)

The motorised vertical awning fits elegantly into the awning's front profile.

- Glare protection and privacy shield up to a maximum valance height of 210 cm
- Extends to any length
- Awning can be set to any angle from 10° to 20°
- Valance Plus cannot be retrofitted

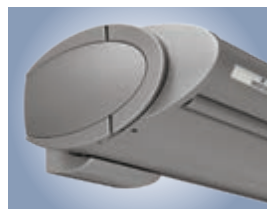

Motorised



Gear drive



Closed

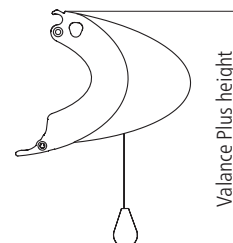

## Maximum awning size for Valance Plus

Motorised main drive			
Width	500 cm	Projection	350 cm
Width	600 cm	Projection	300 cm

## V-shaped waves

On wider units and units which are mounted with special facades technology (distance tube, spreader plates, into insulated walls) symmetric v-shaped waves can occur from the sides. Reason for this, are the weight and structure on the fabric and the bending of the roller tube, which are transferring additional load onto the main brackets and the special fixings.

## Available fabrics for the Valance Plus

	Soltis® 86, 92	Soltis® 86, 92	Acrylic	Perluca		Polyester**		Star-Screen	Fibreglass screen		
Pattern	unicolour	unicolour	stripes	unicolour	unicolour	unicolour	unicolour	stripes	unicolour	unicolour	
Roll width	177 cm	267 cm	120 cm	120 cm	240 cm	120 cm	240 cm	120 cm	120 cm	325 cm	max. 320 cm*
Valance length											
100 cm	N	N	L	N	N	N/L	N	L	N	N	N
150 cm	N	N	Q	Q	N	Q	N	Q	Q	N	N
210 cm	Q	N	Q	Q	N	Q	N	Q	Q	N	-

N Seamless: seamless fabric; structure of fabric runs crosswise to structure of awning fabric

Q Transverse seam: fabric with transverse seam; either in top or bottom third as desired; structure of fabric runs diagonally to structure of awning fabric

L Longitudinal seam: structure of fabric runs longitudinally to structure of awning fabric

- Not available

\* Max. roll widths are stipulated in the collection brochure

\*\* The following designs are not available for Valance Plus: 6-334, 6-335, 6-390, 6-397, 6-400, 6-403, 6-409, 6-410, 6-415  
Please note: On the gear-driven Valance Plus, it is possible that the Valance Plus bottom rail will close unevenly.



# Opal Design II Controls

weinor BiConnect radio technology

01

Product	Electronics	BiConnect control	Remote receiver	Transmitter
Opal Design II	Opal Design II drive	<ul style="list-style-type: none"> <li>• BiRec receiver integrated into cassette</li> </ul>	BiRec MA-K	<ul style="list-style-type: none"> <li>• BiEasy 1M/5M/15M Go! hand transmitter</li> <li>• 1MW-3V wall transmitter</li> </ul>
Opal Design II LED	Opal Design II drive and LED lighting	<ul style="list-style-type: none"> <li>• BiRec combi-receiver for main drive and LED spotlights (with integrated power supply pack) integrated into cassette</li> <li>• Dimmable LED</li> </ul>	BiRec MLED	<ul style="list-style-type: none"> <li>• BiEasy 5M/15M Go! hand transmitter</li> </ul>
Opal Design II Valance Plus	Opal Design II and Valance Plus drive	<ul style="list-style-type: none"> <li>• BiRec combi-receiver for main drive and Valance Plus drive integrated into cassette</li> <li>• Table clearing protection</li> <li>• Gradual soft stop</li> </ul>	BiRec MVLED	<ul style="list-style-type: none"> <li>• BiEasy 5M/15M Go! hand transmitter</li> </ul>
Opal Design II LED Valance Plus	Opal Design II and Valance Plus drive and LED lighting	<ul style="list-style-type: none"> <li>• BiRec combi-receiver for main drive, Valance Plus drive and LED spotlights (with integrated power supply pack) integrated into cassette</li> <li>• Dimmable LED</li> <li>• Table clearing protection</li> <li>• Gradual soft stop</li> </ul>	BiRec MVLED	<ul style="list-style-type: none"> <li>• BiEasy 5M/15M Go! hand transmitter</li> </ul>
Accessories (optional)	Tempura/Tempura Quadra heating system	<ul style="list-style-type: none"> <li>• Dimmable, additional receiver required</li> <li>• Installation of the receiver in the design bar provided for this purpose or the Tempura Quadra box</li> </ul>	BiRec HD	<ul style="list-style-type: none"> <li>• BiEasy 5M/15M Go! hand transmitter</li> </ul>

Requires: awning with BiConnect remote control and sensors require a BiEasy 1M, 5M or 15M Go!



## Exclusive retraction protection

- Co-ordinated retraction: first the Valance Plus, then the awning
- To make sure nothing gets knocked over on the terrace

## Opal Design II Controls

### Somfy io-homecontrol® radio technology

Product	Electronics	Somfy io-homecontrol control	Remote receiver	Transmitter
Opal Design II	Opal Design II drive	<ul style="list-style-type: none"> <li>Somfy io remote-controlled motor integrated into cassette</li> </ul>	Somfy io remote-controlled motor	<ul style="list-style-type: none"> <li>Situo 1 io Pure II/Situo 5 io Pure II/Situo 5 Variation A/M io Pure II hand transmitter</li> <li>Smooove 1 io Pure Shine wall transmitter</li> </ul>
Opal Design II LED	Opal Design II drive and LED lighting	<ul style="list-style-type: none"> <li>Somfy io remote-controlled motor integrated into cassette</li> <li>Additional Somfy receiver for the LED spotlights (with downstream power supply pack) integrated into cassette</li> <li>LED dimmable</li> </ul>	Somfy io remote-controlled motor and io Lighting Receiver Variation (dimmable)	<ul style="list-style-type: none"> <li>Situo 5 io Pure II/Situo 5 Variation A/M io Pure II hand transmitter</li> </ul>
Opal Design II Valance Plus	Opal Design II and Valance Plus drive	<ul style="list-style-type: none"> <li>Somfy io remote-controlled motor integrated into cassette and drop profile</li> <li>No retraction protection in windy conditions</li> </ul>	Somfy io remote-controlled motors	<ul style="list-style-type: none"> <li>Situo 5 io Pure II/Situo 5 Variation A/M io Pure II hand transmitter</li> </ul>
Opal Design II LED Valance Plus	Opal Design II and Valance Plus drive and LED lighting	<ul style="list-style-type: none"> <li>Somfy io remote-controlled motor integrated into cassette and drop profile</li> <li>Additional Somfy receiver for the LED spotlights (with downstream power supply pack) integrated into cassette</li> <li>LED dimmable</li> <li>No retraction protection in windy conditions</li> </ul>	Somfy io remote-controlled motor and io Lighting Receiver Variation (dimmable)	<ul style="list-style-type: none"> <li>Situo 5 io Pure II/Situo 5 Variation A/M io Pure II hand transmitter</li> </ul>
Accessories (optional)	Tempura/Tempura Quadra heating system	<ul style="list-style-type: none"> <li>Dimmable, additional receiver required</li> <li>Installation of the receiver in the design bar provided for this purpose or the Tempura Quadra box</li> </ul>	Heating Receiver Variation io 1.5 kW STAS3/STAK3 (dimmable)	<ul style="list-style-type: none"> <li>Situo 5 io Pure II/Situo 5 Variation A/M io Pure II hand transmitter</li> <li>Smooove 1 io Pure Shine wall transmitter</li> </ul>

Note: For Somfy io in combination with LED, two transformer boxes are used.

### Somfy RTS radio technology

Product	Electronics	Somfy RTS control	Remote receiver	Transmitter
Opal Design II	Opal Design II drive	<ul style="list-style-type: none"> <li>Somfy RTS remote-controlled motor integrated into cassette</li> </ul>	Somfy RTS remote-controlled motor	<ul style="list-style-type: none"> <li>Situo 1 RTS Pure II/Situo 1 Soliris RTS Pure II/Situo 5 RTS Pure II/Situo 5 Soliris RTS Pure II hand transmitter</li> <li>Smooove 1 RTS Pure Shine wall transmitter</li> </ul>
Opal Design II LED	Opal Design II drive and LED lighting	<ul style="list-style-type: none"> <li>Somfy RTS remote-controlled motor integrated into cassette</li> <li>Additional Somfy receiver for the LED spotlights (with downstream power supply pack) integrated into cassette</li> <li>LED not dimmable</li> </ul>	Somfy RTS remote-controlled motor and Lighting Slim Receiver RTS	<ul style="list-style-type: none"> <li>Situo 5 RTS Pure II/Situo 5 Soliris RTS Pure II hand transmitter</li> </ul>
Opal Design II Valance Plus	Opal Design II and Valance Plus drive	<ul style="list-style-type: none"> <li>Somfy RTS remote-controlled motor integrated into cassette</li> <li>Additional Somfy receiver for Valance Plus drive integrated into cassette</li> <li>No retraction protection in windy conditions</li> </ul>	Somfy RTS remote-controlled motor and Universal Receiver RTS	<ul style="list-style-type: none"> <li>Situo 5 RTS Pure II/Situo 5 Soliris RTS Pure II hand transmitter</li> </ul>
Opal Design II LED Valance Plus	Opal Design II and Valance Plus drive and LED lighting	<ul style="list-style-type: none"> <li>Additional Somfy receiver for Valance Plus drive and LED spotlights (with downstream power supply pack) integrated into cassette</li> <li>LED not dimmable</li> <li>No retraction protection in windy conditions</li> </ul>	Somfy RTS remote-controlled motor, Universal Receiver RTS and Lighting Slim Receiver RTS	<ul style="list-style-type: none"> <li>Situo 5 RTS Pure II/Situo 5 Soliris RTS Pure II hand transmitter</li> </ul>
Accessories (optional)	Tempura/Tempura Quadra heating system	<ul style="list-style-type: none"> <li>Not dimmable, additional receiver required</li> <li>Installation of the receiver in the design bar provided for this purpose or the Tempura Quadra box</li> </ul>	Heating Slim Receiver RTS Plug	<ul style="list-style-type: none"> <li>Situo 5 RTS Pure II/Situo 5 Soliris RTS Pure II hand transmitter</li> </ul>

Note: For Somfy RTS in combination with LED and Valance Plus, two transformer boxes are used.

## Hard wired with Somfy control

Product	Electronics	Hard wired Somfy control	Control
Opal Design II	Opal Design II drive	<ul style="list-style-type: none"> <li>• Somfy control for awning drive</li> </ul>	e.g. Soliris Smoove Uno
Opal Design II LED	Opal Design II drive and LED lighting	<ul style="list-style-type: none"> <li>• Somfy control for awning drive</li> <li>• Switch on site for the LED spotlights</li> <li>• LED power supply pack integrated into the cassette</li> <li>• LED not dimmable</li> </ul>	e.g. Soliris Smoove Uno and suitable light switch (on site)
Opal Design II Valance Plus	Opal Design II and Valance Plus drive	<ul style="list-style-type: none"> <li>• Somfy control for awning drive</li> <li>• Switch on site for the Valance Plus drive</li> <li>• No retraction protection in windy conditions</li> </ul>	e.g. Soliris Smoove Uno and suitable double rocker switch (on site)
Opal Design II LED Valance Plus	Opal Design II and Valance Plus drive and LED lighting	<ul style="list-style-type: none"> <li>• Somfy control for awning drive</li> <li>• Switch on site for the Valance Plus drive</li> <li>• No retraction protection in windy conditions</li> <li>• Switch on site for the LED spotlights</li> <li>• LED power supply pack integrated into the cassette</li> <li>• LED not dimmable</li> </ul>	e.g. Soliris Smoove Uno, and suitable double rocker switch and light switch (on site)
Accessories (optional)	Tempura/Tempura Quadra heating system	<ul style="list-style-type: none"> <li>• Not dimmable</li> </ul>	Suitable switch (on site)

## Hard wired (existing switch/power supply on site)

Product	Electronics	Hard wired control	Control
Opal Design II	Opal Design II drive	<ul style="list-style-type: none"> <li>• Awning switch for the awning drive</li> </ul>	e.g. double rocker switch switch (on site)
Opal Design II LED	Opal Design II drive and LED lighting	<ul style="list-style-type: none"> <li>• Awning switch for the awning drive</li> <li>• Switch on site for the LED spotlights</li> <li>• LED power supply pack integrated into the cassette</li> <li>• LED not dimmable</li> </ul>	e.g. double rocker switch and suitable light switch (on site)
Opal Design II Valance Plus	Opal Design II and Valance Plus drive	<ul style="list-style-type: none"> <li>• Awning switch for the awning drive</li> <li>• Switch on site for the Valance Plus drive</li> <li>• No retraction protection in windy conditions</li> </ul>	e.g. 2 double rocker switches (on site)
Opal Design II LED Valance Plus	Opal Design II and Valance Plus drive and LED lighting	<ul style="list-style-type: none"> <li>• Awning switch for the awning drive</li> <li>• Switch on site for the Valance Plus drive</li> <li>• No retraction protection in windy conditions</li> <li>• Switch on site for the LED spotlights</li> <li>• LED power supply pack integrated into the cassette</li> <li>• LED not dimmable</li> </ul>	e.g. 2 double rocker switches and suitable light switch (on site)
Accessories (optional)	Tempura/Tempura Quadra heating system	<ul style="list-style-type: none"> <li>• Not dimmable</li> </ul>	Suitable switch (on site)



**Note:**

Please see the "Accessories" technical brochure for further details regarding the drive and control.

Some options are subject to a surcharge. For prices, please refer to the weinor awnings price list.

# Opal Design II Planning

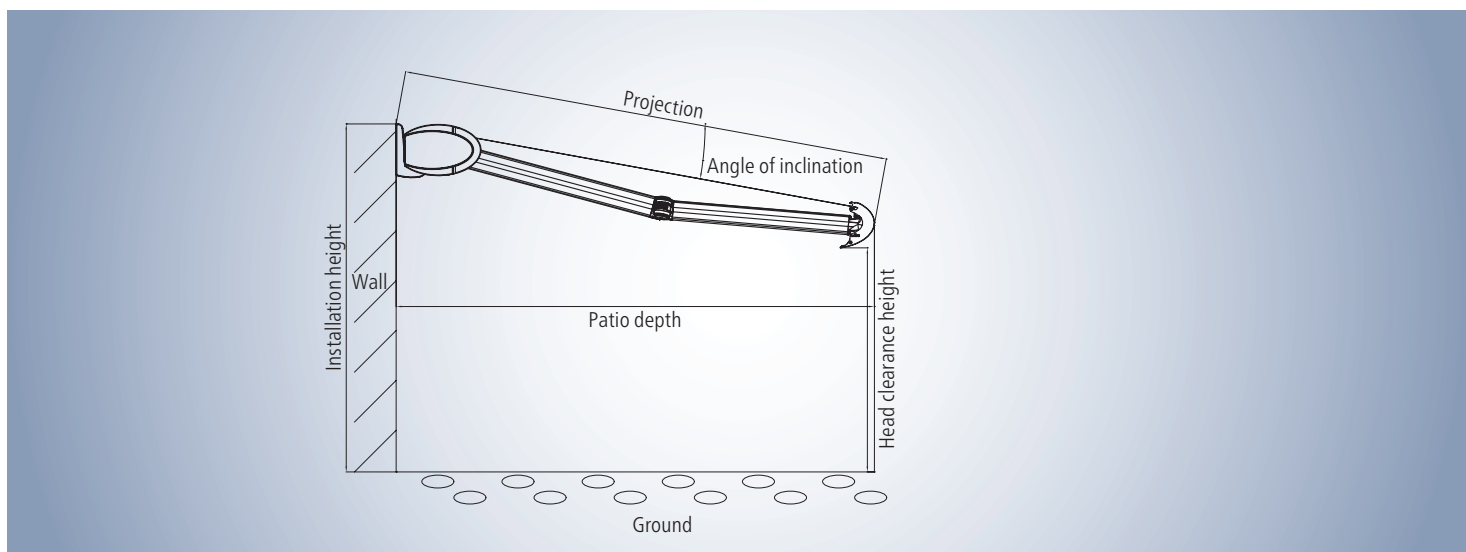

## Site measurements – Determining the projection and head clearance height

- Find the projection by looking in the “Projection” table for the terrace depth.
- Using the projection from the table and the required angle of inclination, consult the “head clearance height” table for the head clearance height. This head clearance height refers to an installation height of 300 cm.
- Add/subtract the difference between 300 cm and the actual installation height to/from the head clearance height in the table.

### Determining the projection

Angle of pitch	Terrace depth in cm					
	150	200	250	300	350	400
5°	150	200	250	300	350	400
15°	160	210	260	310	360	400
25°	170	220	280	330	390	400

Projection in cm (rounded figures)

This table can be used to find the awning projection for any given horizontal patio depth.

### Determining the head clearance height

Angle of pitch	Projection in cm					
	150	200	250	300	350	400
5°	275	270	270	260	260	250
15°	250	240	220	210	200	190
25°	220	200	180	160	140	120

Head clearance height in cm (rounded figures)

This table is used to find the head clearance heights for various projections when the angle of pitch is 5°, 15° or 25°.

This table is based on the example of an installation height of 300 cm (upper edge of awning).

Wall bracket

Sizes and bracket recommendations

Wall mounting on pressure-resistant surface

Minimum number of required wall brackets so that the function of the awning is ensured, regardless of the mounting surface. Selection of the brackets using the weinor bracket overview and using the maximum extraction forces of the fixings used!



Width in cm	Diagonal in 10 cm steps					
	up to 150	160-200	210-250	260-300	310-350	360-400
up to 200	2					
201-250	2	2				
251-300	2	2	2			
301-350	2	2	2	2	2	2
351-400	2	2	2	2	2	2
401-450	2	2	2	2	2	2
451-500	2	2	2	2	2	2
501-550	3	3	3	3	3	3
551-600	3	3	3	3	3	3
601-650	3	3	3	3	3	3

- 2 2 x wall bracket 150 mm
- 3 3 x wall bracket 150 mm (1 x as centre bracket)

Use of central bracket dependent on:  
Width ≥ 501 cm

Observe size limits; unit must have 50 cm more width than projection!

Position of wall brackets and Opal Design II cassette

Wall bracket 150 mm (left and right)

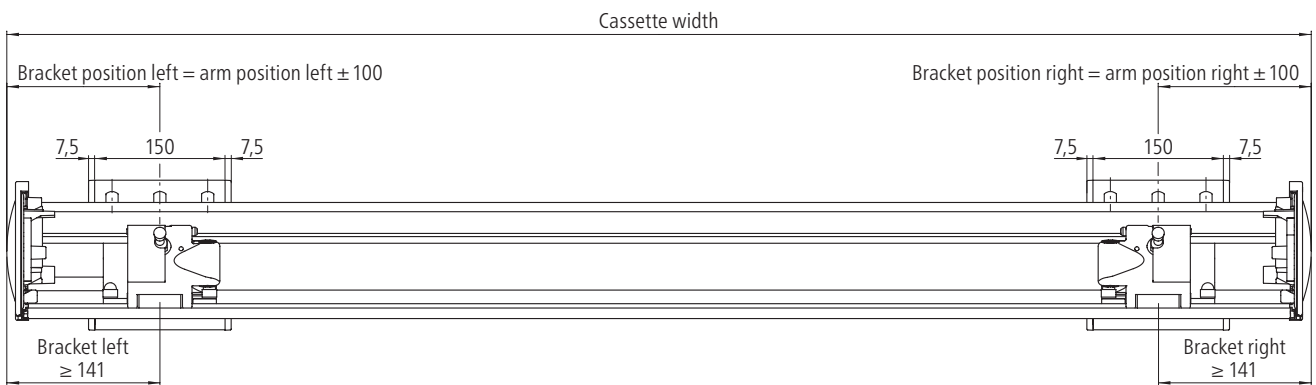

**Position of wall brackets and Opal Design II cassette**

**Wall bracket 150 mm (left, right and centre)**

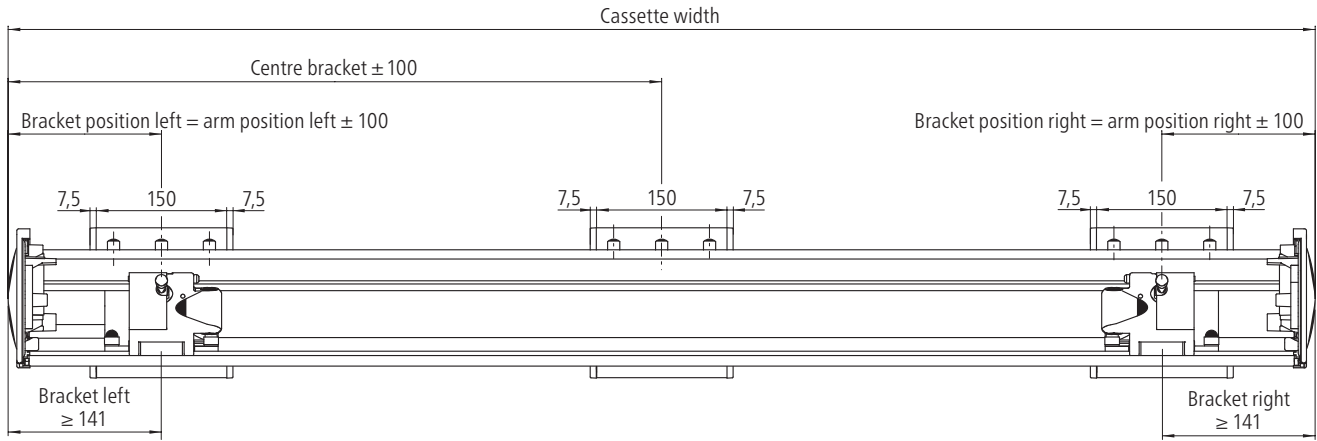

**Wall bracket 300 mm (left and right)**

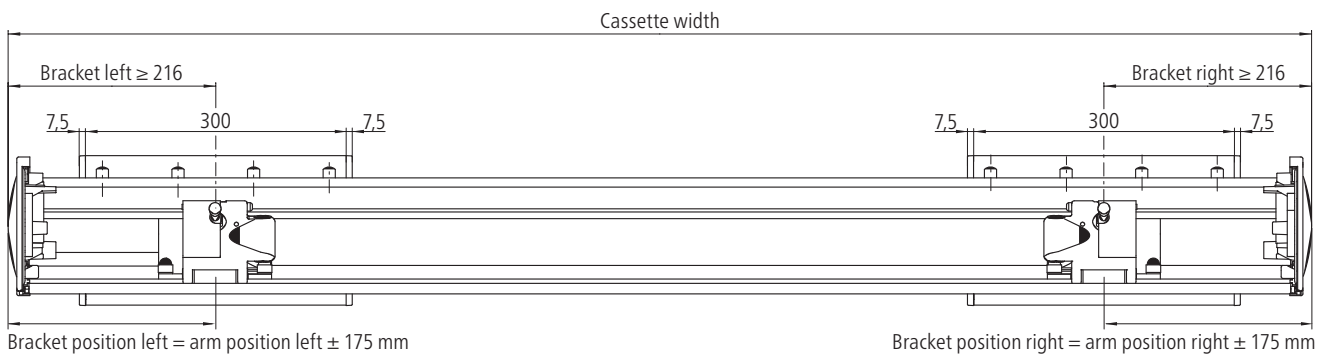

**Wall bracket 300 mm (left and right) with wall bracket 150 mm (centre)**

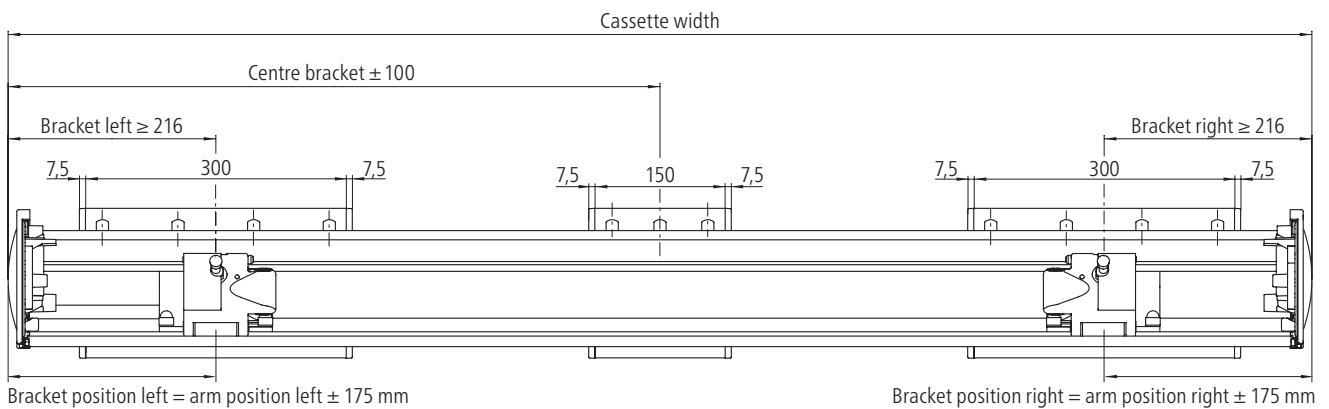

## Cross-sections

Opal Design II LED

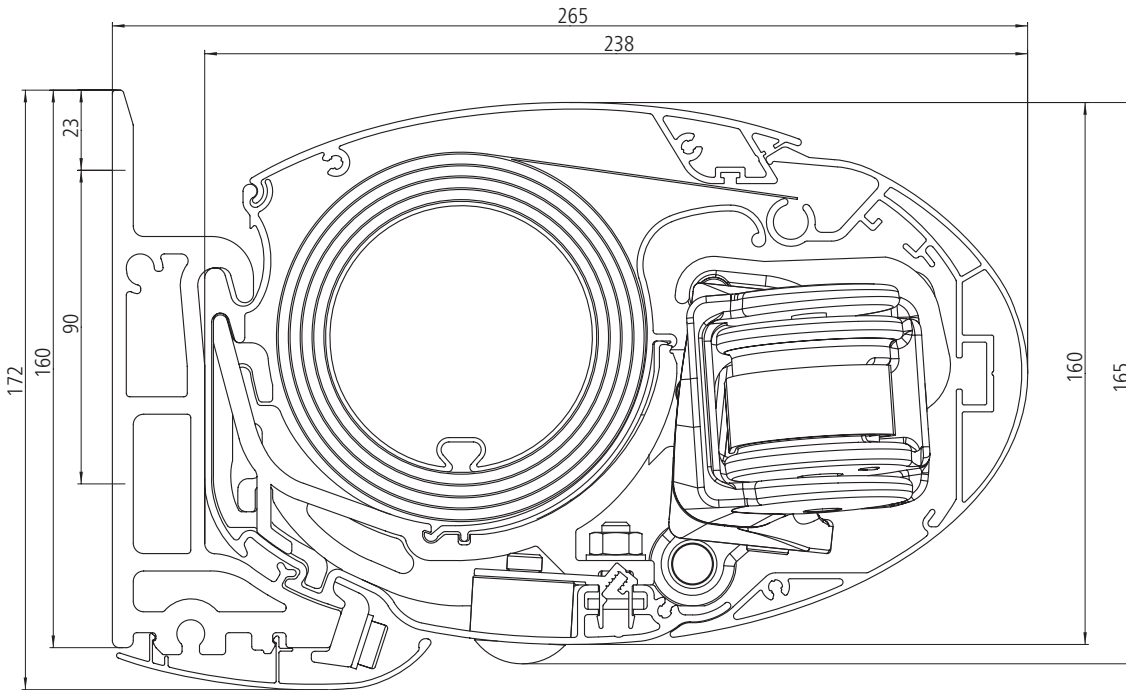

Opal Design II LED Valance Plus with motor

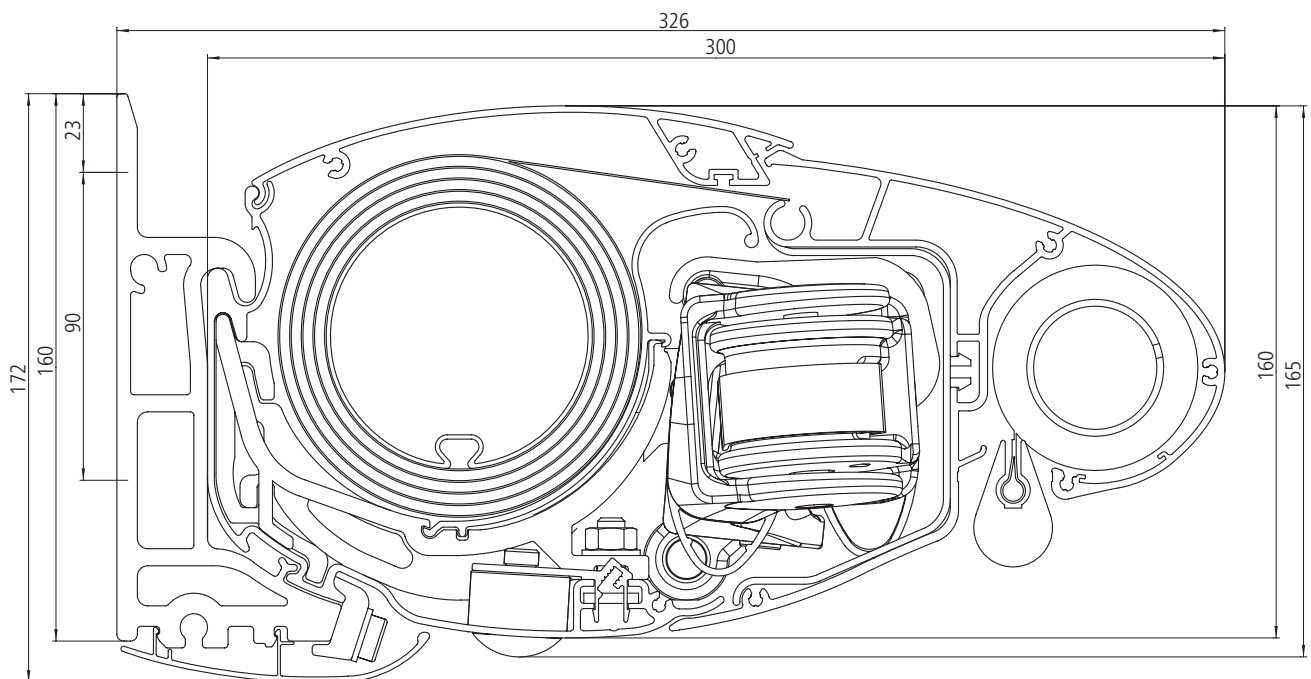

Figures are in mm

# Opal Design II Installation

## Wall mounting – brackets



Wall bracket

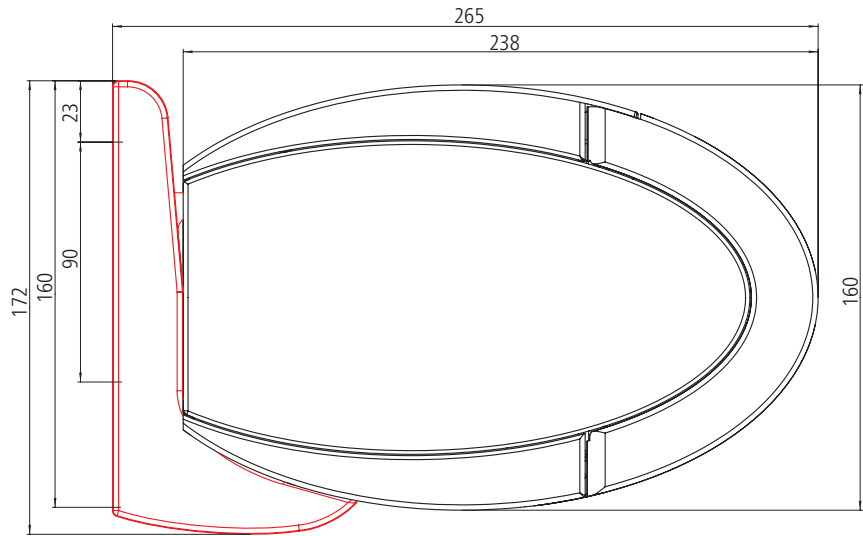

Wall bracket 150 mm

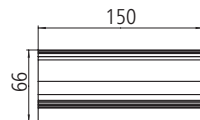
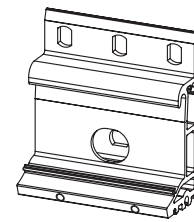
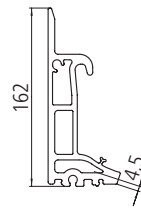
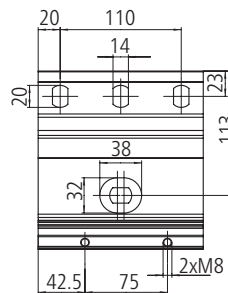

Wall bracket 300 mm

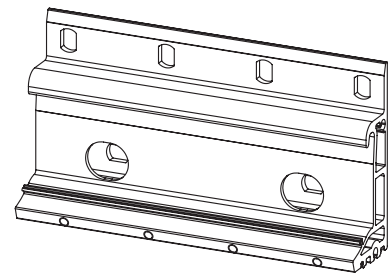
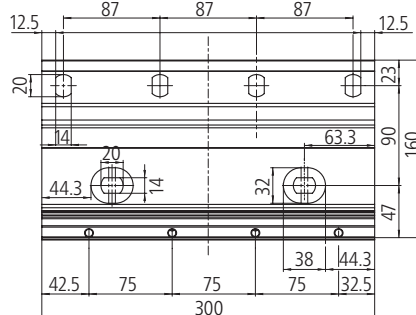



## Wall mounting – mounting plates



Mounting plate 660 x 220 x 15 mm

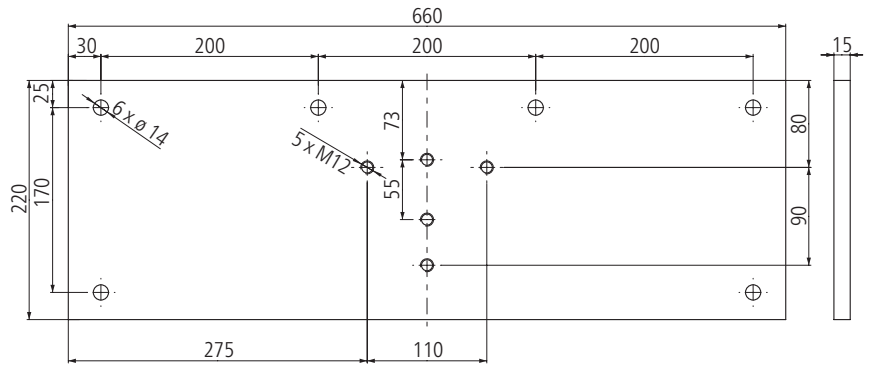

Position of the mounting plates using the Opal Design II 500 x 300 cm\* as an example.

\* Depending on the width of the awning, the positioning of the mounting plates may vary.



Mounting plate 660 x 390 x 15 mm

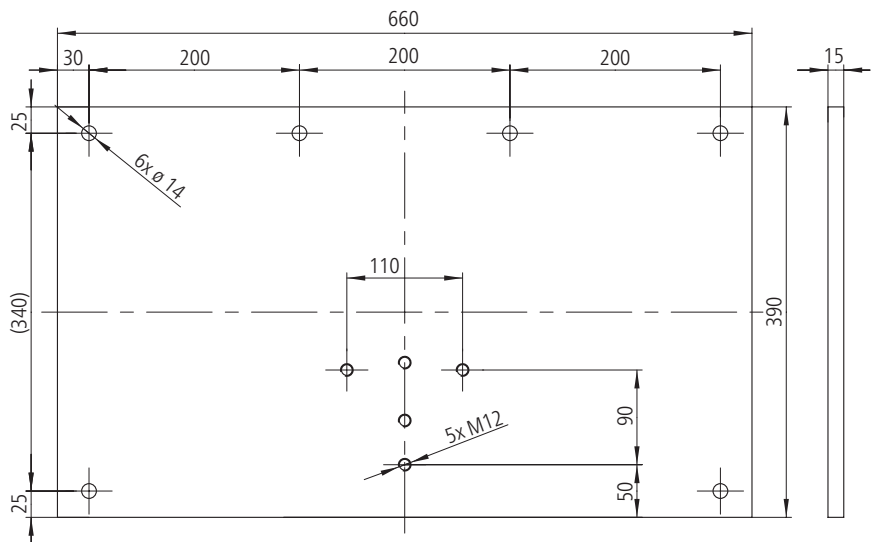
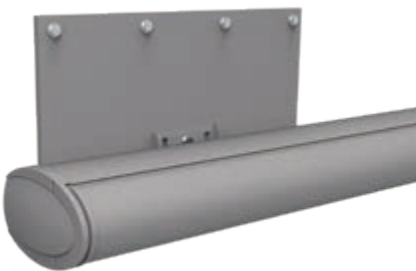

Position of the mounting plates using the Opal Design II 500 x 300 cm\* as an example.



Ceiling front plate 410 x 160 x 15 mm

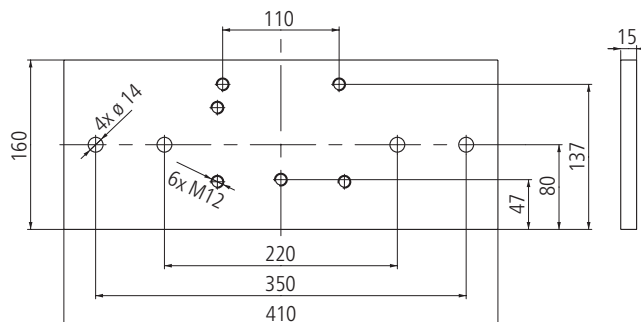

### Note for front ceiling mounting:

The indicated extraction forces apply to a storey ceiling with a thickness of at least 160 mm. Here, the fixings are installed exactly in the centre of the storey ceiling, so that there is a minimum upward and downward edge distance of 80 mm. For this mounting type, a lining, e.g. with 150 x 50 mm rectangular pipes, is required. Here, the lower edge of the rectangular pipe must be flush with the lower edge of the storey ceiling.

## Opal Design II Installation

### Minimum spacing distances for installation in the niche (wall mounting)

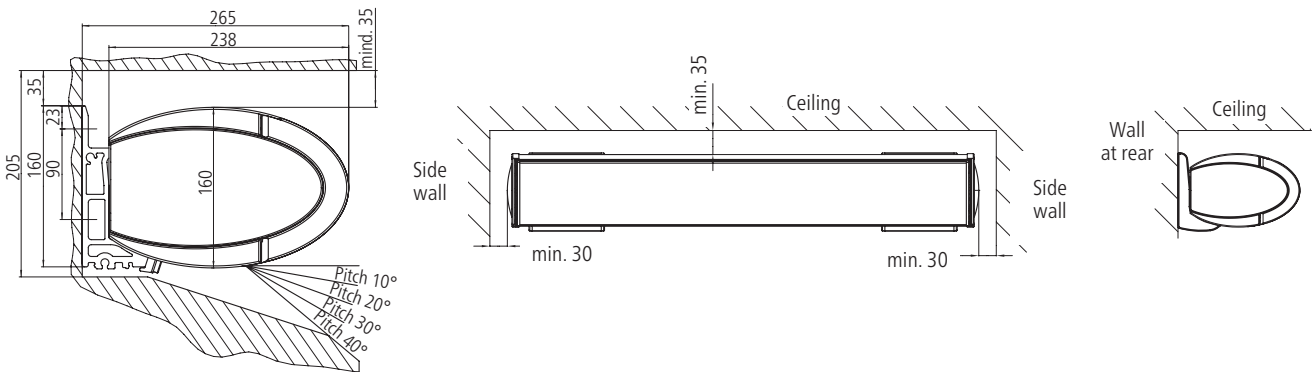

### Ceiling mounting



Ceiling bracket

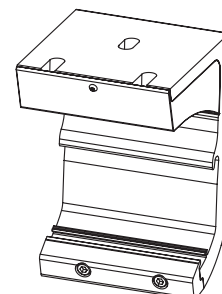
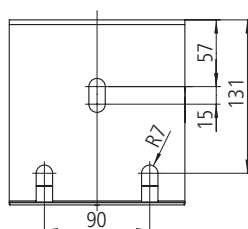
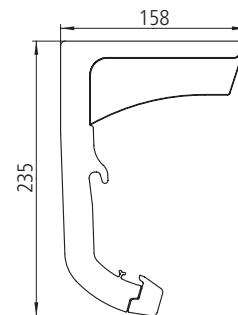
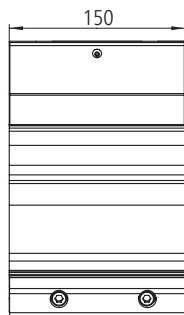
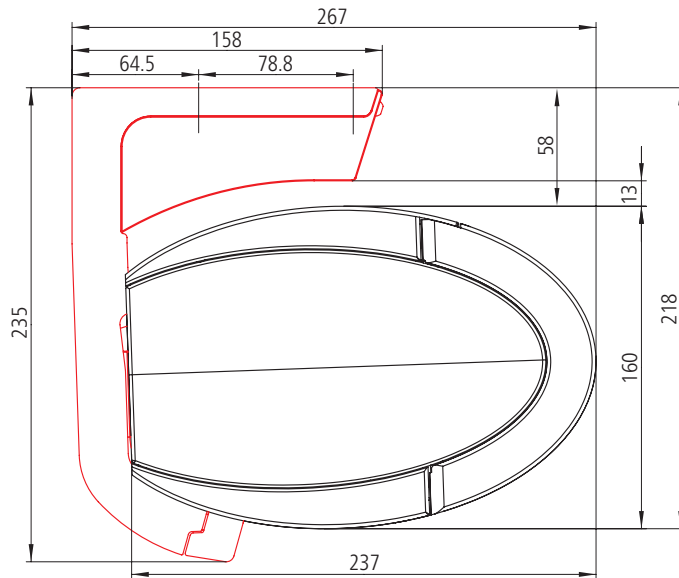

## Rafter mounting

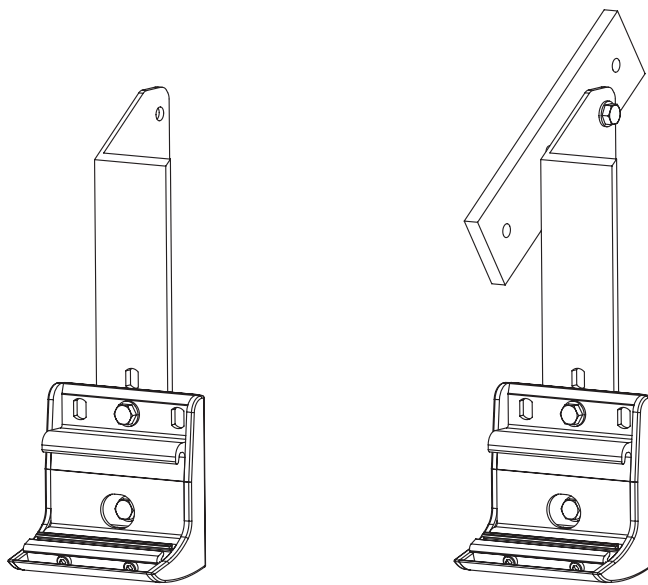

Right-hand rafter bracket

Rafter bracket with mounting plate for right-hand rafter bracket. weinor recommends using a mounting plate for the rafter bracket.

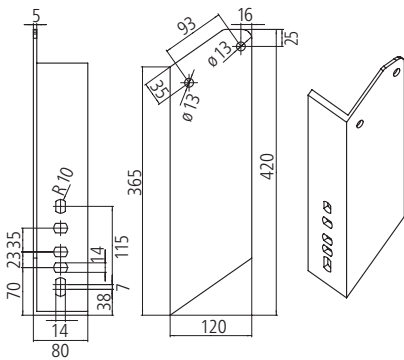

Rafter bracket

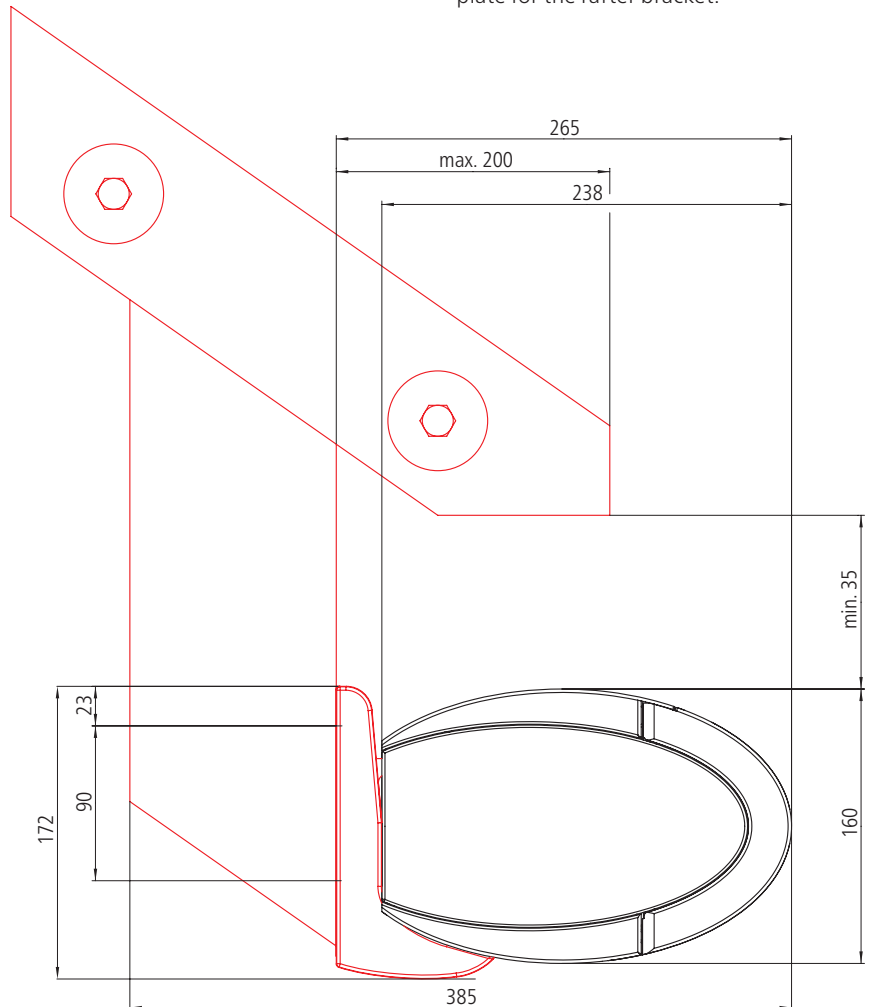

Side view: rafter bracket installation

# Opal Design II Installation

## Extraction forces

The extraction force is the force with which the awning weight and the wind load pull on each upper and/or front fixing. The tables indicate this force in N per upper fixing. It varies depending on the awning size and the wall bracket / mounting plate used.

### Selecting the wall bracket and anchoring system:

1. Consult relevant table for extraction force per fixing for selected awning size.
2. Select a wall bracket / mounting plate for which there is fixing material which can resist the indicated extraction force. Remember to take into account the spacing, the area which will be damaged if the fixing breaks out, the type of fixing material used and the mounting base.

Use the separate bracket overview for an exact planning of the awning attachment.

### Extraction force in N per upper fixing for ceiling mounting

Brackets **without** mounting plates

**Wall mounting** with up to 200 mm facing (non-pressure-resistant surface)

Please observe the width to projection dimension limits

For the extraction forces of the valance plus version, please refer to the console overview!

 1 x wall bracket 150 mm  
Number of fixings: 6

 1 x wall bracket 300 mm  
Number of fixings: 12

**Please note:**  
from a width of 501 cm additional  
1 x wall bracket 150 mm  
as centre bracket is required.  
This means an additional 3 fixings will be  
required.

Width in cm	Projection in cm					
	150	200	250	300	350	400
200	678					
	339					
250	801	1192				
	400	596				
300	923	1375	1930			
	462	688	965			
350	1046	1558	2184	2955		
	523	779	1092	1478		
400	1168	1740	2438	3291	4187	
	584	870	1219	1645	2093	
450	1291	1923	2691	3626	4614	6565
	645	962	1346	1813	2307	3282
500	1413	2106	2945	3962	5684	7181
	707	1053	1473	1981	2842	3590
550	1536	2289	3199	4297	6178	7797
	768	1144	1599	2149	3089	3899
600	1658	2471	3452	5210	6672	8414
	829	1236	1726	2605	3336	4207
650	1781	2654	3706	5595	7166	9030
	890	1327	1853	2797	3583	4515

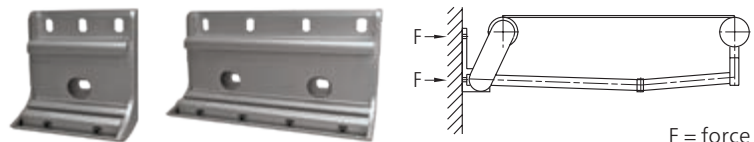

## Extraction forces

### Extraction force in N per upper fixing for ceiling mounting

Brackets **with** mounting plates

**Wall mounting** with up to 200 mm facing (non-pressure-resistant surface)

Please observe the width to projection dimension limits

For the extraction forces of the valance plus version, please refer to the console overview!

1 x mounting plate  
660 x 220 x 15 mm incl.  
1 x wall bracket 150 mm  
Number of fixings: 12

1 x mounting plate  
660 x 390 x 15 mm incl.  
1 x wall bracket 150 mm  
Number of fixings: 12

1 x roof front plate  
410 x 160 x 15 mm incl.  
1 x wall bracket 150 mm  
Number of fixings: 8

**Please note:**

from a width of 501 cm additional

1 x wall bracket 150 mm incl.

1 x shim plate 15 mm

as centre bracket is required.

This means an additional 3 fixings will be required.

When mounting with roof front plate:

1 x roof front plate 410 x 160 x 15 mm incl.

1 x wall bracket 150 mm

as centre bracket is required.

This means an additional 4 fixings will be required.

Width in cm	Projection in cm					
	150	200	250	300	350	400
200	182					
	91					
	386					
250	215	319				
	107	159				
	456	678				
300	247	368	515			
	124	184	258			
	526	781	1095			
350	280	417	583	788		
	140	208	292	394		
	596	885	1239	1675		
400	313	465	651	878	1116	
	157	233	325	439	558	
	665	989	1383	1865	2370	
450	346	514	718	967	1229	1748
	173	257	359	484	615	874
	735	1093	1527	2055	2613	3715
500	379	563	786	1056	1515	1912
	189	282	393	528	757	956
	805	1196	1671	2245	3219	4063
550	411	612	854	1146	1646	2076
	206	306	427	573	823	1038
	874	1300	1815	2435	3498	4412
600	444	661	922	1390	1778	2240
	222	330	461	695	889	1120
	944	1404	1958	2953	3778	4761
650	477	709	989	1492	1909	2405
	239	355	495	746	955	1202
	1014	1508	2102	3171	4058	5110



Mounting plate using the example 660 x 220 x 15 mm

# Opal Design II Installation

## Extraction forces / Shear forces

### Extraction force in N per front fixing for ceiling mounting

Please observe the width to projection dimension limits

For the extraction forces of the valance plus version, please refer to the console overview!

 1 x ceiling bracket 150 mm  
Number of fixings: 6

**Please note:**  
from a width of 501 cm additional 1 x ceiling bracket 150 mm as centre bracket is required. This means an additional 3 fixings will be required.

Width in cm	Projection in cm					
	150	200	250	300	350	400
200	546					
250	640	925				
300	733	1062	1467			
350	827	1199	1656	2221		
400	921	1336	1845	2469	3125	
450	1014	1473	2033	2717	3441	4858
500	1108	1611	2222	2965	4213	5311
550	1159	1704	2365	3166	4527	5712
600	1249	1838	2551	3819	4886	6161
650	1340	1972	2736	4099	5246	6610

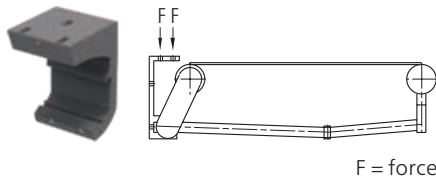

### Shear forces in N per fixing for rafter mounting

Please observe the width to projection dimension limits

For the extraction forces of the valance plus version, please refer to the console overview!

 1 x rafter bracket incl.  
1 x wall bracket 150 mm,  
one left, one right for each

 1 x rafter bracket with  
1 x mounting plate for rafter  
incl.  
1 x wall bracket 150 mm,  
one left, one right for each

**Please note:**  
from a width of 501 cm additional 1 x rafter bracket incl. 1 x wall bracket 150 mm, one left, one right for each, as centre bracket is required.

Width in cm	Projection in cm					
	150	200	250	300	350	400
200	1447					
	656					
250	1701	2469				
	767	1080				
300	1955	2840	3928			
	877	1238	1682			
350	2209	3212	4438	5949		
	988	1396	1896	2512		
400	2463	3584	4948	6618	8365	
	1099	1555	2110	2791	3500	
450	2717	3956	5458	7287	9214	13021
	1209	1713	2325	3069	3852	5397
500	2972	4327	5969	7956	11318	14238
	1320	1871	2539	3348	4711	5897
550	3161	4633	6410	8554	12223	15377
	1366	1964	2685	3556	5041	6321
600	3411	5000	6916	10349	13196	16589
	1473	2117	2895	4287	5441	6816
650	3661	5367	7421	11111	14170	17801
	1579	2271	3105	4600	5840	7312

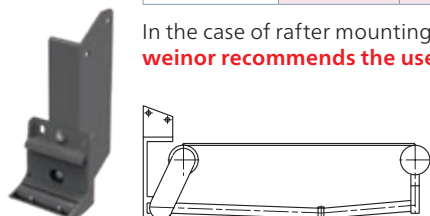

In the case of rafter mounting, the fixings are included in the order.  
**weinor recommends the use of rafter brackets with mounting plate!**

## CONTACT US



# ShadeZone

Alfresco Specialists

The S Zone UK Limited, Unit B4 -B5 Citadel Trading Estate,  
Citadel Way, Hull, HU9 1TQ. United Kingdom

Telephone: +44 (0)1482 219919 | Email: [info@s-zone.co.uk](mailto:info@s-zone.co.uk)  
[www.shadezone.co.uk](http://www.shadezone.co.uk)